



## KR40 DRILL RIG

### Technical Parameters & Configuration

Name	Unit	Value
Max. torque	kN.m	40
Max. diameter	mm	1200
Max. drilling depth	m	12
Speed of rotation	rpm	7~30
Width of track plate	mm	450
Max. crowd pressure	kN	70
Max. crowd pull	KN	70
Main winch line pull	kN	45
Main winch line speed	m/min	30
Main winch line pull	kN	45
Auxiliary winch line pull	kN	10
Auxiliary winch line speed	m/min	38
Stroke (crowd system)	mm	600
Slewing speed	rpm	5
Mast inclination (lateral)	°	±6°
Mast inclination (forward)	°	+90°
Pilot pressure	Mpa	3.9
Max. operating pressure	Mpa	28.5
Max. tractive force	KN	64
Operation height	mm	7920
Operation width	mm	2260
Transport height	mm	2270
Transport width	mm	2260
Transport length	mm	9410
Total weight including Kelly Bar	ton	14

Working & Transport State

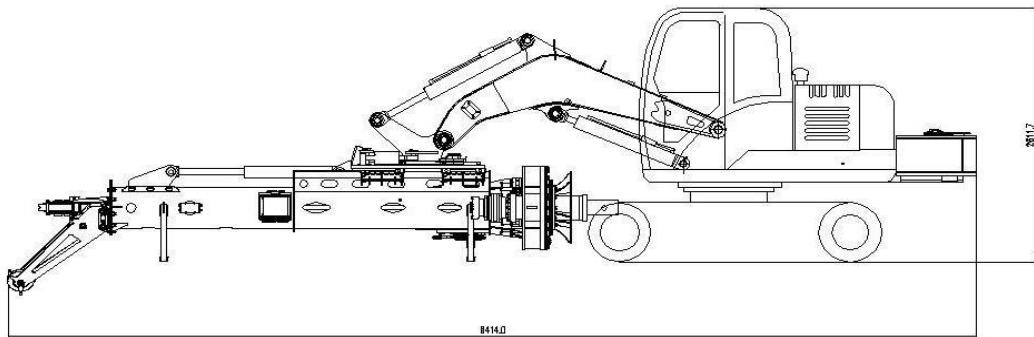
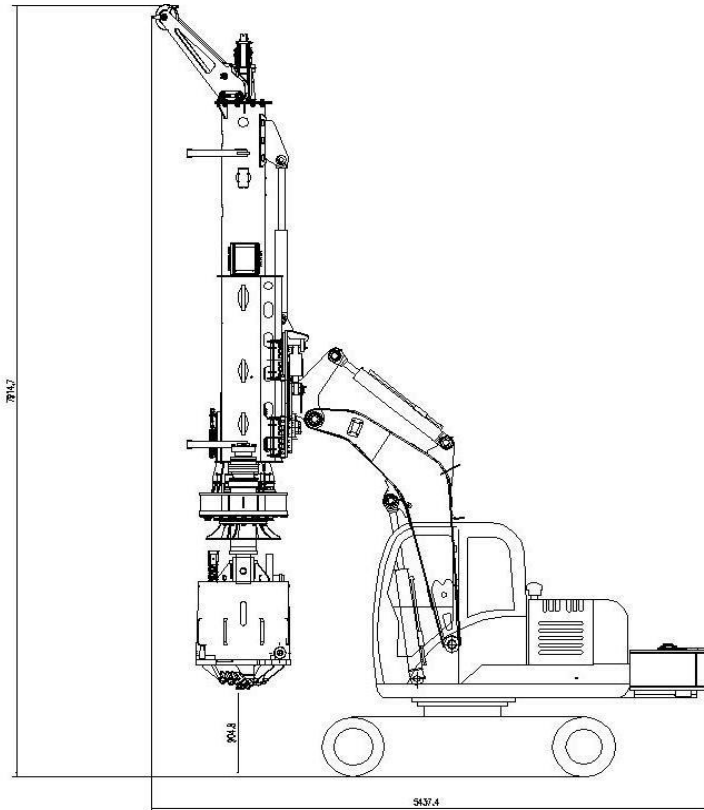

HIRE

MANUKAU

15 MANA PLACE WIRI

102 LANGLEY ROAD WIRI

NORTHSHORE

17 KAHIKATEA FLAT ROAD DAIRY FLAT

ENGINEERING

102 LANGLEY ROAD WIRI

[WWW.FACEBOOK.COM/PILEHIRE](http://WWW.FACEBOOK.COM/PILEHIRE)

[WWW.LINKEDIN.COM/IN/PILEHIRE-LTD-00711182](http://WWW.LINKEDIN.COM/IN/PILEHIRE-LTD-00711182)



[WWW.PILEHIRE.CO.NZ](http://WWW.PILEHIRE.CO.NZ)  
0800 HIRE IT